

SCM7B

Module Dimensions and Pinouts

The following mechanical drawing is useful if designing circuit boards to mount the SCM7B modules. Many sockets are available which accept the mounting pins. As an example, AMP Inc. provides a socket with part number 50865-5.

The captive nut for the 4-40 mounting screw can be obtained from PEM (Penn Engineering and Manufacturing), part number KSF2-440 ET.

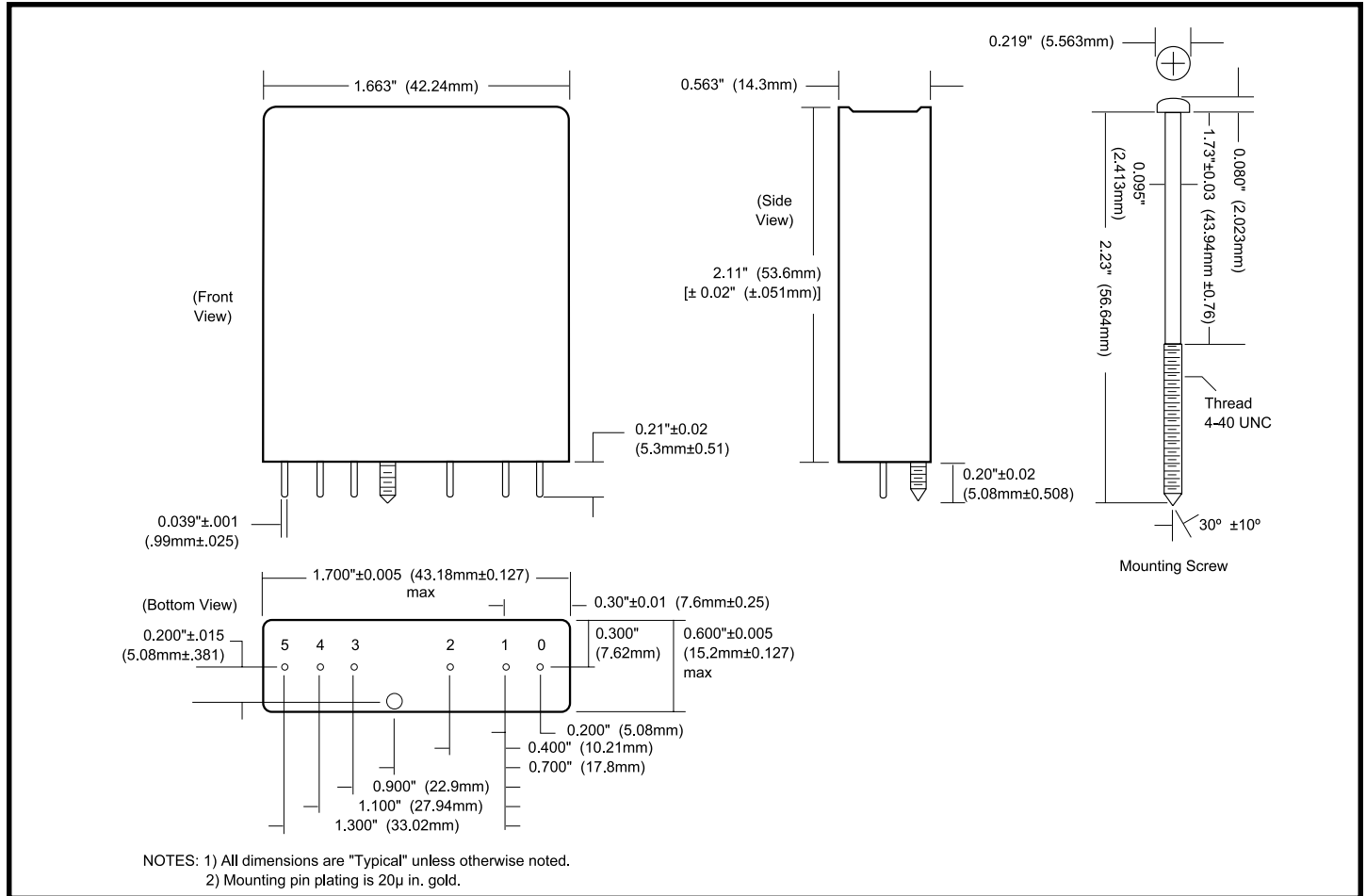

Figure 1: SCM7B Module Dimensions

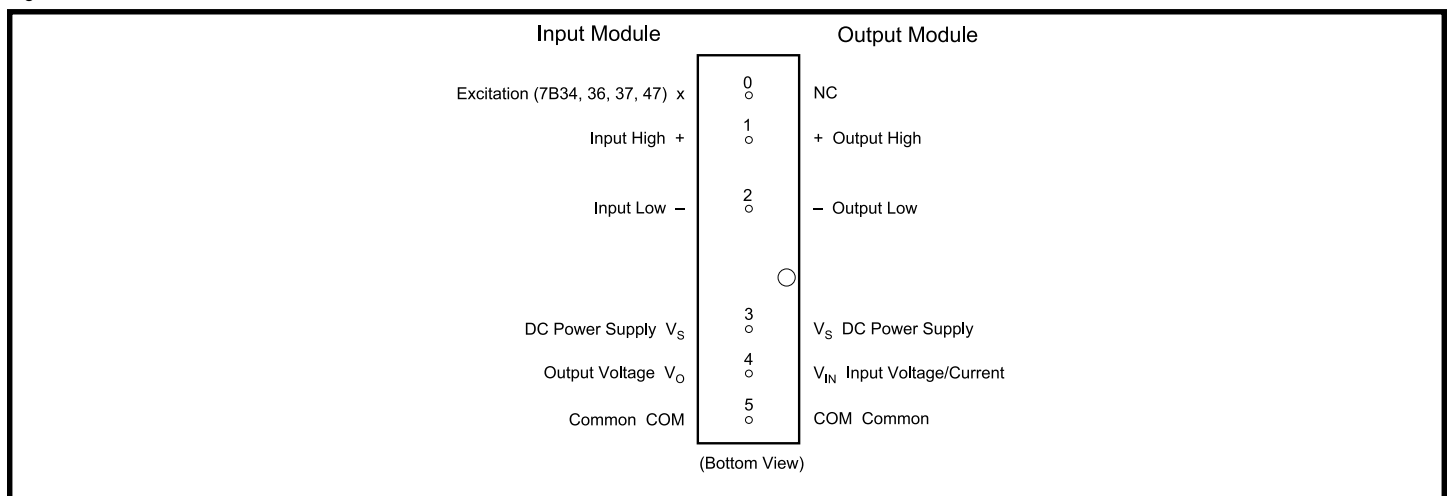

Figure 2: SCM7B Pinouts